

81 SERIES

AMAZON

4 1/4" MINI BAG FILTER HOUSING

The **81 SERIES - MINI** 4 1/4" bag housing is available in both single and double lengths. The top opening style is equipped with a Vee clamp as standard for pressures up to 8.5 bar g. These housings are widely used where low cost is of prime importance and this makes them the ideal choice to replace conventional cast stainless steel strainers. The side inlet and bottom outlet configuration is perfectly suited to duties where product changes demand a simple to clean, easy access housing. With only the basket to remove, quick and efficient cleaning is possible with the **81 SERIES - MINI** housing.

Bolted closures and heating jackets are options available for all models.

The **81 SERIES - MINI** housing will accept the full range of Amazon and industry standard bags ranging from 1 to 1000µm with nominal lengths of 7" (P3) and 14" (P4).

Product Features

- Quick release Vee clamp closure for ease of access rated at 8.5 bar g
- Flat bolted closure for high pressure rated at FV / 10 bar g
- Internally and externally electropolished as standard
- Robust bag support basket assembly fabricated from perforated sheet rather than wire mesh for extra strength
- Wide range of options available for connection sizes and types and materials of construction
- Available in 316L stainless steel
- PED and Compliant



Accessories

Pressure Gauge and Vent Valve Kit



Pressure Gauge and Auto Vent Valve Kit



Displacement Pod



81 SERIES FEATURES AND BENEFITS

- Integral vent to aid efficient filter changeout
- Each housing is etched with a unique serial number for full traceability
- Full housing customisation service available
- Internally and externally electropolished as standard

81 SERIES

TECHNICAL DATA

Maximum Operating Conditions

Pressure Range: Liquid: Vee clamp: 8.5 bar g
Screw clamps: FV / 10 bar g
Gases: Screw clamps: FV / 10 bar g
Temperature Range: Vee clamp: -10°C / 110°C
Screw clamps: -10°C / 150°C

Materials of Construction

Body: 316L St. Steel
Closure: Vee clamp - 304 St. Steel
Screw clamps - Zinc plated carbon steel
(Optional stainless steel)

Finish

Vessel: Electropolished
Basket: Pickled

Connections

Inlet/Outlet: 1", 1.5" or 2" BSPM
Vent: 1/4" BSP

Model	Dimensions					Volume (Litres)	Dry Weight
	A	B	C	D	E		
81011MVN10A1EE	324	48	-	115	200	2.9	3.7
81012MVN15A1EE	483	48	-	115	350	4.8	5.2
81012MVN20A1EE	481	48	-	110	350	4.8	5.2

PED Status:

Fluid Groups: Compliant with 97/23/EC
Liquids Groups 1+2
Gases Groups 2 (Screw clamps only)
Marking: Sound Engineering Practice
ATEX: Compliant 94/9/EC, level CE Ex II 2 GD c X

Technical drawings for each individual housing showing dimensions, volume, weights, maximum temperatures and design pressures available on request.

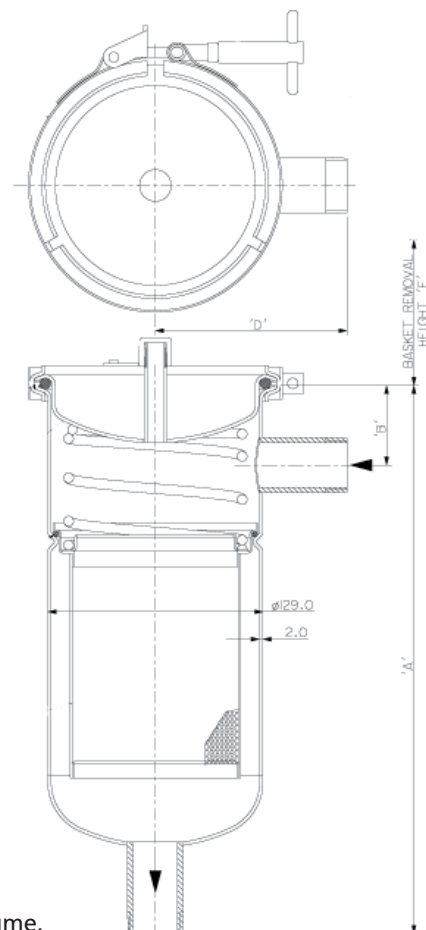

AMAZON FILTERS LTD.

ALBANY PARK ESTATE, FRIMLEY ROAD,
CAMBERLEY, SURREY, GU16 7PG
ENGLAND

Tel: +44 (0) 1276 670 600

Fax: +44 (0) 1276 670 101

Email: sales@amazonfilters.co.uk

Web: www.amazonfilters.com



Certificate No. FM39584

Distributed by: