

66 SERIES

AMAZON

MULTI CARTRIDGE HIGH FLOW HOUSING



The **66 SERIES** housing range is specifically designed for use with large diameter **SUPAPLEAT HFC** cartridges to provide a liquid filtration system that offers maximum efficiency, high flow rates and long life. This range of multi-cartridge housings can accommodate 3,4,5 and 7 filter cartridges in either 40" or 60" lengths. The housings are designed to be used in a horizontal orientation and have a hinged and bolted closure to enable easy opening and closing. These housings are particularly suited to large scale high flow applications. The use of high surface area large diameter cartridges, instead of standard diameter cartridges, can greatly reduce the time required for filter change-out.

These high quality 316L stainless steel housings come fitted with an integral stand and are available with a choice of connection types and sizes. To provide maximum convenience and safety, vent and drain ports are provided both upstream and downstream and the housing is fitted with lifting lugs. The housings are finished with a high quality external bead blast.

The **66 SERIES** housings can accommodate filters manufactured with either polypropylene or glass microfibre media and with removal ratings of 0.5 – 90µm. Therefore they are suitable for a wide range of applications including water treatment and the production of beverages, chemicals and pharmaceuticals.

Product Features

- Designed for high flow systems
- Easy and quick cartridge change-out
- Suitable for 3,4,5 or 7 cartridges
- Available for 40" or 60" filters
- Manufactured from 316L stainless steel
- High quality finish
- Each housing is hydrostatically pressure tested
- Available with a range of connection types and sizes
- Supplied with an integral stand
- Rated at FV / 10 bar in liquids
- PED Compliance - CE Marked



66 SERIES FEATURES AND BENEFITS

- Designed for **SUPAPLEAT HFC** cartridges for maximum flow rates
- Accommodates 3,4,5 and 7 cartridges of either 40" or 60" length so suitable for a wider range of applications
- Utilises large diameter cartridges allowing quick filter change-out
- Operated in the horizontal orientation and fitted with a hinged and bolted closure for easy access
- Each housing is etched with a unique serial number for full traceability
- Full housing customisation service available

66 SERIES

TECHNICAL DATA

Maximum Operating Conditions

Pressure Range: FV / 10 bar g
 Temperature Range: -10°C / 110°C

Materials of Construction

Body and Closure: 316L St. Steel
 Vessel Finish: Pickle, passivate and external bead blast

Connections

Inlet/Outlet: 6" - 12" Flange
 Vent: 1" BSPM with Cap
 Drain: 1" BSPM with Cap
 Lid vent: ½" BSPF with Plug

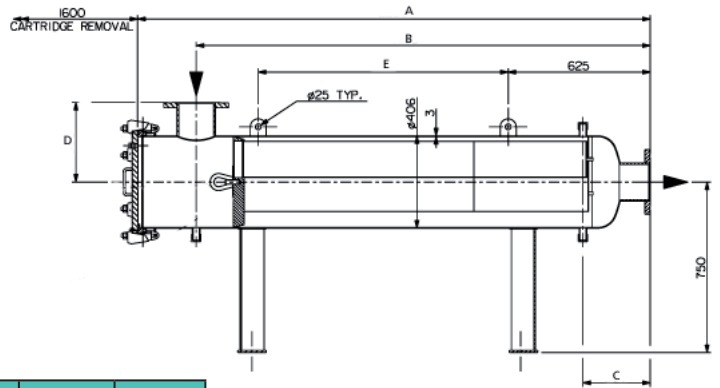

Model	Dimensions					Volume (Litres)	Dry Weight
	A	B	C	D	E		
66034CHD60C1GE	1753	1495	296	350	1100	206	211
66036CHD60C1GE	2256	1998	296	350	1600	269	228
66044CHD80C1GE	1748	1492	297	394	1100	260	285
66046CHD80C1GE	2251	1995	297	394	1600	340	310
66054CHDA1C1GE	1817	1532	358	400	1100	337	357
66056CHDA1C1GE	2320	2035	358	400	1600	436	384
66074CHDA2C1GE	1861	1538	395	450	1100	498	555
66076CHDA2C1GE	2364	2041	395	450	1600	640	594

PED Status: Compliant with 97/23/EC
Fluid Groups: Liquid Groups 1 + 2
Marking: CE Marked
Exceptions: Group 1 liquids - Explosive
ATEX: Compliant 94/9/EC, level CE Ex II 2 GD c X

AMAZON FILTERS LTD.

ALBANY PARK ESTATE, FRIMLEY ROAD,
 CAMBERLEY, SURREY, GU16 7PG
 ENGLAND

Tel: +44 (0) 1276 670 600

Fax: +44 (0) 1276 670 101

Email: sales@amazonfilters.co.uk

Web: www.amazonfilters.com



Certificate No. FM39584

Distributed by: