

# 88 SERIES

AMAZON

## MULTI POT BAG HOUSING

The **88 SERIES** multi bag housings are designed for use with the industry standard **DUOLINE G** Series 7" ring style bag. The top opening style is equipped with a Rathmann style bolted closure as standard for pressures up to 10 bar g. A robust design with side in and bottom outlet connection, the **88 SERIES** is ideal for high flow, high dirt volume applications, where free draining and frequent process changes will take place.

Widely used in the paint, chemical & petrochemical industries the **88 SERIES** is available for 4, 6, 8 and 12 bags. With the Rathmann style bolted closure as standard and manual davit, its simple operation has proved highly successful in many applications around the world. The high build quality and wide ranging options list make these vessels suitable for all high flow bag applications.

The housing will accept the full range of Amazon and industry standard bags ranging from 1 to 1000µm with nominal lengths of 16" (P1), 32" (P2) and Amazon's own 48" triple length bag.

### Product Features

- Standard bolted style closure
- Conventional dished end to aid cleardown
- Bead blasted finish inside and outside
- Wide range of options available for connection sizes, types and materials of construction
- Positive bag sealing mechanism to minimise risk of seal bypass
- Robust bag support basket assembly fabricated from perforated sheet rather than wire mesh for extra strength
- Rated at 10 bar liquid
- PED and ATEX Compliant



### Accessories

Pressure Gauge and Vent Valve Kit



Pressure Gauge and Auto Vent Valve Kit



Displacement Pod



## 88 SERIES FEATURES AND BENEFITS

- Wide range of options available for connection sizes and types and materials of construction
- Each housing is etched with a unique serial number for full traceability
- Full housing customisation service available

88 SERIES

## TECHNICAL DATA

### Maximum Operating Conditions

Pressure Range: FV / 10 bar g  
 Temperature Range: -10°C / 110°C

### Materials of Construction

Body and Closure: 316L St. Steel  
 304 St. Steel

### Finish

Vessel: Bead Blast  
 Basket: Pickled

### Connections

Inlet/Outlet: 4" Flanged  
 Vent: ½" BSPF with Plug  
 Drain: 1" BSPM

Model	Dimensions					Volume (Litres)	Dry Weight
	A	B	C	D	E		
88041UJB40C**E	1123	990	350	375	400	238	253
88042UJB40C**E	1483	1350	350	375	750	247	286
88043UJB40C**E	1865	1730	350	375	1150	338	320

**PED Status:** Compliant with 97/23/EC  
**Fluid Groups:** Liquids Group 1 + 2  
**Marking:** CE Marked  
**Exceptions:** Group 1 liquids - Explosive  
**ATEX:** Compliant 94/9/EC, level CE Ex II 2 GD c X

Technical drawings for each individual housing showing dimensions, volume, weights, maximum temperatures and design pressures available on request.

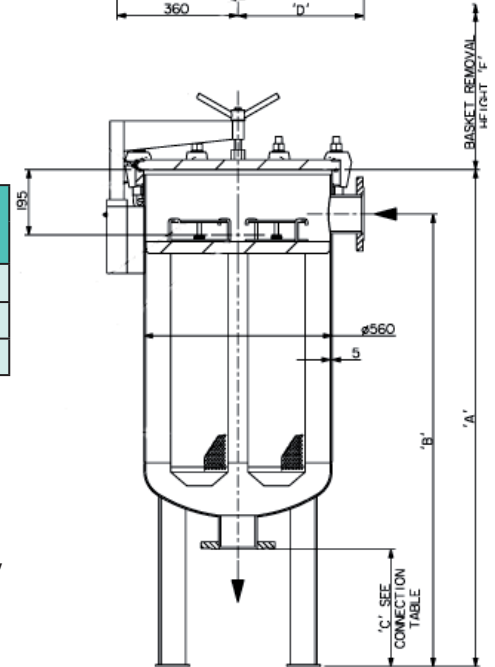
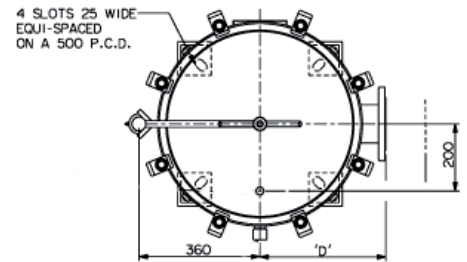

## AMAZON FILTERS LTD.

ALBANY PARK ESTATE, FRIMLEY ROAD,  
 CAMBERLEY, SURREY, GU16 7PG  
 ENGLAND

Tel: +44 (0) 1276 670 600

Fax: +44 (0) 1276 670 101

Email: sales@amazonfilters.co.uk

Web: www.amazonfilters.co.uk



Certificate No. FM39584

Distributed by: