

# 74 SERIES

AMAZON

## INLINE SINGLE CARTRIDGE HOUSING



The **74 SERIES** single cartridge housing is available for elements up to 20" long. The inline, plenum style configuration is ideally suited to both liquid and gas processes for pressures up to 10 bar.g.

Mounted inline, this plenum styled housing will suit processes where there is a need to allow easy access to all internal areas, therefore assisting in the general cleanliness of the process system in which the filter is to operate. Having no loose internal components ensures easy and fast clean down procedures.

The **74 SERIES** housing will accept the Single Open End Code 7 cartridge with nominal lengths of 10 and 20".

### Product Features:

- Inline style construction with an industrial bead blasted finish, inside and out
- DIN locking nut style closure for ease of access
- No loose internals for trouble free operation.
- Easy drain plenum feature for gas applications
- 4 different vent options
- PED and ATEX compliant
- CE Marked

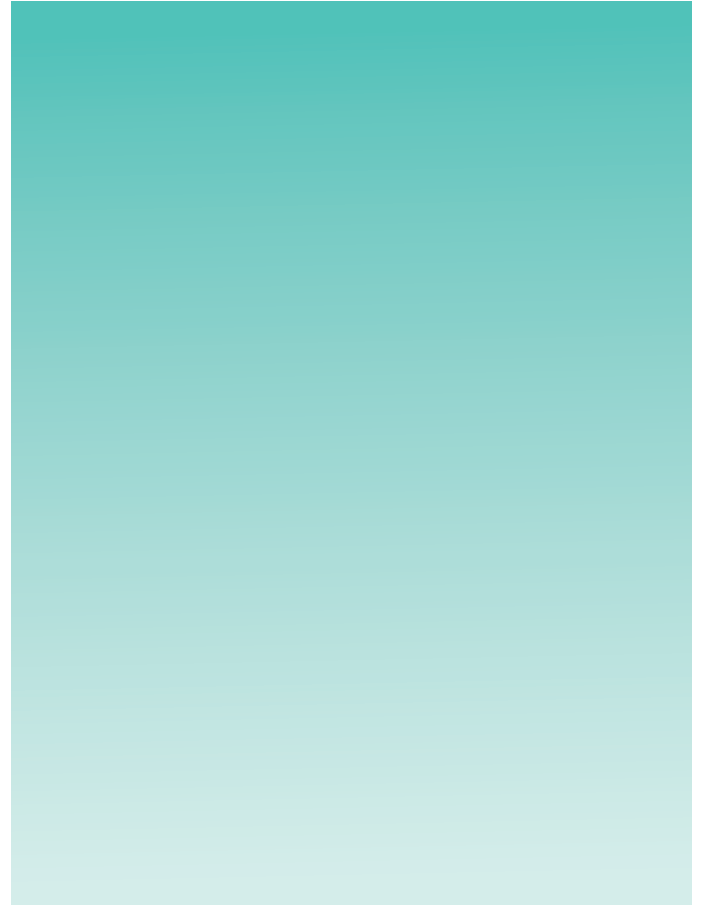

## 74 SERIES FEATURES AND BENEFITS

- Standard single open end cartridge fitting, using the Bayonet lock code 7 for forward and reverse flow
- 316L construction for maximum corrosion resistance.
- Every housing is etched with a serial number for full traceability.
- Wide range of options available for connection size and style, cartridge lengths and materials of construction
- Full certification available, PED and ATEX compliant, CE Marked

74 SERIES

## TECHNICAL DATA

### Operating Conditions

Maximum Pressure: Liquid: 10 bar.g  
Gas: 10 bar.g  
Maximum Temperature: 110°C

### Materials of Construction

Body and Closure: 316L St. Steel  
Clamp: 304 St. Steel

### Finish

Vessel: Pickle, bead blast internal/external

### Connections

Inlet/Outlet: 1½ Hygenic Coupling  
Vent: ¼" BSPF  
Drain: ¼" BSPF

Model	Dimensions					Volume (Litres)	Dry Weight
	A	B	C	D	E		
74011XF15N1GE	436	68	-	249	350	3.8	5.2
74012XF15N1GE	691	68	-	249	600	5.7	6.5

### PED Status:

Compliant 97/23/EC  
Gas Group 2

### Marking:

Liquids Group 1 + 2  
CE - 20" (Gas Group 2)  
(SEP) Sound Engineering Practice - 10"  
(Gas Group 2)

### Exceptions: ATEX:

Group 1 liquids - Explosive  
Compliant 94/9/EC, level CE Ex II 2 GD c X

Technical drawings for each housing showing dimensions, volume and weights available on request.

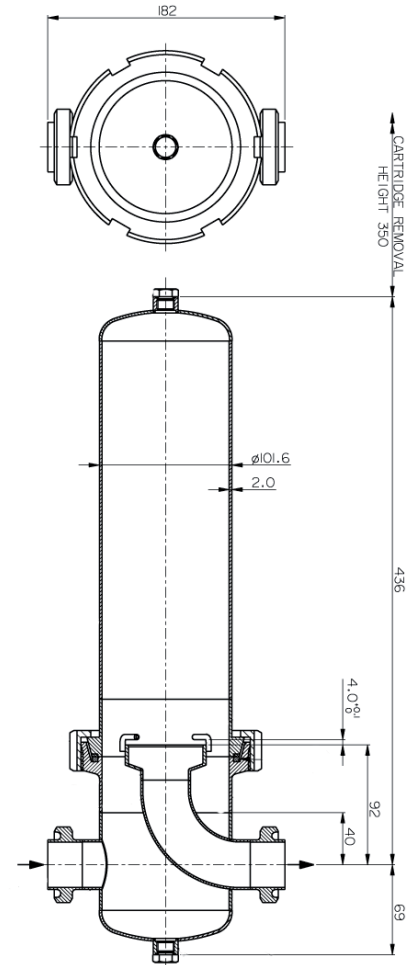

## AMAZON FILTERS LTD.

ALBANY PARK ESTATE, FRIMLEY ROAD,  
CAMBERLEY, SURREY, GU16 7PG  
ENGLAND

Tel: +44 (0) 1276 670 600

Fax: +44 (0) 1276 670 101

Email: [sales@amazonfilters.co.uk](mailto:sales@amazonfilters.co.uk)

Web: [www.amazonfilters.co.uk](http://www.amazonfilters.co.uk)



Certificate No. FM39584

Distributed by: