

62 SERIES

AMAZON

3-15 ROUND CARTRIDGE HOUSINGS

The **62 SERIES** Multi cartridge housing range is designed to accommodate 3, 5, 10, 15, 19, 24 or 30 stacks of filter cartridges up to 40" long. The top opening style is equipped with a Cast Vee clamp as standard for pressures ranging from 6 - 10 bar g. Leg mounted and equipped with the more conventional dished end, these housings suit processes where there is a need to allow complete drainage of the clean chamber. This design assists in maintaining the general cleanliness of the process system. With the ability to accept both standard Double Open End and Single Open End cartridges, this leg mounted, free standing housing will suit most applications. Bolted closures are an option available for all models.

The **62 SERIES** will accept the full range of Amazon and industry standard cartridges ranging from 0.1 to 500µm with nominal lengths of 10, 20, 30 and 40".

For information on housings suitable for 19, 24 and 30 cartridges refer to datasheet '**62 Series - 19-30 Round Cartridge Housings**'.

Product Features:

- Dished bottom end allows complete drainage of clean chamber, leading to improved system cleanliness
- Adjustable strap legs on the 3 and 5 round housings allow the user to set inlet and outlet heights
- Vee clamp closures use unique 'W' style seal for reliable leak free operation
- High quality cast Vee band clamps for safety and security
- Cast compression nut with integral PTFE washer for easy, hand tight cartridge sealing
- Wide range of connection sizes and types, cartridge lengths and materials of construction
- PED and ATEX Compliant



Accessories

Pressure Gauge and Vent Valve Kit



Pressure Gauge and Auto Vent Valve Kit



Ball Valve and Nipple



62 SERIES FEATURES AND BENEFITS

- Integral vent, clean and dirty drains to aid efficient filter change-out
- Each housing hydrostatically pressure tested
- Internally and externally electropolished as standard
- Each housing is etched with a unique serial number for full traceability
- Full housing customisation service available
- Universal cup enables choice of plug in (Code 3, Code 8 and Code A) or DOE cartridge styles in the same housing

62 SERIES

TECHNICAL DATA

Max Operating Conditions

	6203	6205	6210	6215
Vee Clamp:	10 Bar g	10 Bar g	8.5 Bar g	6 Bar g
Bolted Closure:	10 Bar g	10 Bar g	10 Bar g	10 Bar g
Gas:	6 Bar g	4.5 Bar g	N/A	N/A
Maximum Temperature:	110°C	110°C	110°C	110°C

Materials of Construction

Body:	316L St.Steel
Closure:	Vee Clamp - 304 St.Steel Screw Clamp - Zinc plated carbon steel (Optional Stainless Steel) Electropolished
Vessel Finish:	

Connections

	6203-05	6210	6215
Inlet/Outlet:	2" BSPM	3" Flange	4" Flange
Vent:	1/4" BSP	1/4" BSP	1/2" BSP
Drain:	1/2" BSPM	1/2" BSPM	1" BSPM

PED Status:

Fluid Groups:	Compliant with 97/23/EC Liquids Group 1 + 2 Gas Group 2 (6203 and 6205 only) CE Marked
Marking:	Group 1 liquids - Explosive
Exceptions:	Compliant 94/9/EC, level CE Ex II 2 GD c X
ATEX:	

Technical drawings for each housing showing dimensions, volume and weights available on request.

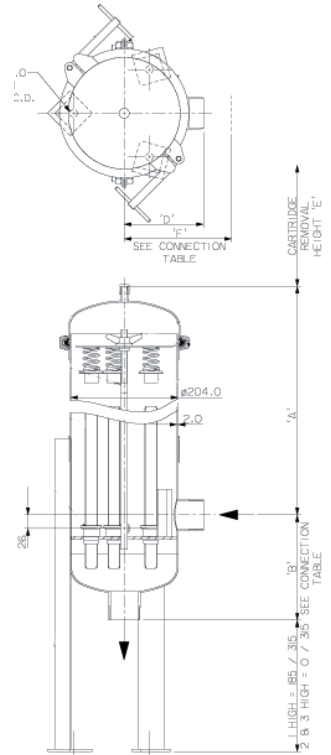

AMAZON FILTERS LTD.

ALBANY PARK ESTATE, FRIMLEY ROAD,
CAMBERLEY, SURREY, GU16 7PG
ENGLAND

Tel: +44 (0) 1276 670 600

Fax: +44 (0) 1276 670 101

Email: sales@amazonfilters.co.uk

Web: www.amazonfilters.co.uk



Certificate No. FM39584

Distributed by: