

56 SERIES

AMAZON

SINGLE STACK FILTER HOUSING

The **56 SERIES** single cartridge housing is renowned for its high quality design and manufacture and accepts both standard Double Open End and Single Open End cartridges. The housing has a high security bolted closure and is particularly suitable for hazardous liquid and gas applications.

The **56 SERIES** will accept the full range of Amazon and industry standard cartridges ranging from 0.1 to 500µm with nominal lengths of 5, 10, 20 and 30".

Product Features:

- High security bolted closure suitable for hazardous applications
- Dual purpose head accepts SOE code 3 and DOE cartridges
- SOE code 7 and code B adaptors available
- Offered with a wide range of connection sizes and types
- Available for a range of cartridge lengths
- PED and ATEX Compliant
- Full traceability on all parts, material certification packs available
- Rated at 10 bar g and full vacuum in liquids
- Rated at 9 bar g and full vacuum in gases



56 SERIES FEATURES AND BENEFITS

- Bolted closure provides high security housing sealing
- Suitable for hazardous liquid and gas applications
- Full vacuum rating in liquids and gases
- Integral vent and drain sockets to aid efficient filter change-out complete with PTFE washer
- Unique interchangeable configuration enables choice of SOE or DOE cartridge styles in the same housing
- Every housing is etched with a serial number for full traceability
- Full housing customisation service available

56 SERIES

TECHNICAL DATA

Maximum Operating Conditions

Pressure Range: Liquid: FV / 10 bar g
 Gas: 10" & 20": FV / 10 bar g
 30": FV / 9 bar g

Temperature Range: -10°C / 150°C

Materials of Construction

Body and Closure: 316L St. Steel
 Hastelloy C22
 Seal: Ethylene Propylene

Finish

Vessel: Externally polished sump, electropolished head

Connections

Inlet/Outlet: 1" BSPF
 Vent: 1/4" BSPF with Plug
 Drain: 1/4" BSPF with Plug

Model	Dimensions					Volume (Litres)	Dry Weight
	A	B	C	D	E		
10"	343	-	-	120	300	2.2	7.2
20"	597	-	-	120	554	3.8	8.2
30"	851	-	-	120	808	5.2	9.2

PED Status: Compliant with 97/23/EC

Fluid Groups: Gas Group 1 + 2
 Liquids Group 1 + 2

Marking: CE Marked

Exceptions: Group 1 liquids - Explosive

ATEX: Compliant 94/9/EC, level CE Ex II 2 GD c X

Technical drawings for each individual housing showing dimensions, volume, weights, maximum temperatures and design pressures available on request.

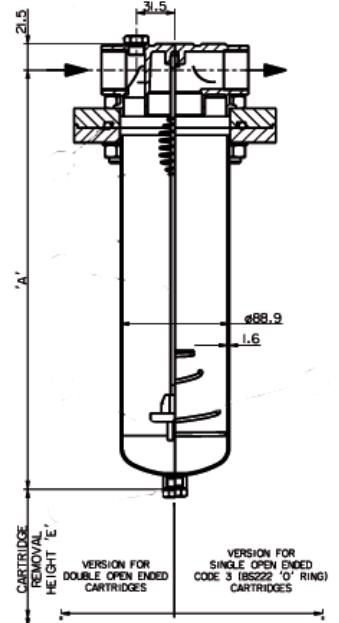
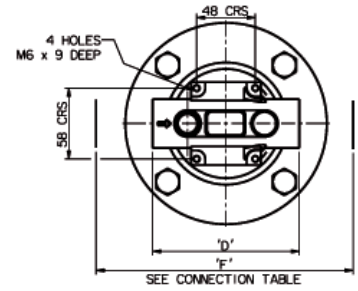

AMAZON FILTERS LTD.

ALBANY PARK ESTATE, FRIMLEY ROAD,
 CAMBERLEY, SURREY, GU16 7PG
 ENGLAND

Tel: +44 (0) 1276 670 600

Fax: +44 (0) 1276 670 101

Email: sales@amazonfilters.co.uk

Web: www.amazonfilters.com



Certificate No. FM39584

Distributed by: